

INNOVATIVE

# EdgeTec Pack Station

TAPERS

## OPERATOR FRIENDLY

The side belt driven Pack Station is designed for compact, packing and sealing. The durable design has proven to be one of the most reliable case tapers on the market today, keeping production and maintenance efforts to a minimum. The Pack Station provides a fast and cost-efficient alternative to hand taping.

## PACKING AND SEALING MADE EASY

Designed with the customer in mind, the Pack Station is supplied with extended side rails, flap closing bars, and a 48" anvil packing station to assist with the packing and sealing process. Operation is simple: open the case and manually fold the bottom front and back minor flaps and place case on the anvil to be filled. Once filled, the operator pushes down and holds the top trailing minor flap while the box enters the machine to be sealed.

## LESS DOWNTIME

Pack Station offers fast and easy case changes with adjustable side rails and flexibility for boxes 5" in length and greater. Adjustments can be made on the fly with easy hand tighten knobs and cranks. Pack Station utilizes EdgeTec's Easy Swap top and bottom tape heads and will seal boxes as narrow as 4.5" wide and as low as 4.5" tall.

## INDUSTRIAL QUALITY

CE approved dual drive motors, aggressive industrial strength side belts and roller tables make Pack Station a workhorse. Each machine is made from 12 gauge steel and will withstand the most rugged applications. The powder coated exterior protects the machine from harsh conditions.

## CONVENIENCE

These machines accept 2" wide pressure-sensitive tape as a standard, or can be ordered with 3" tape heads. The use of EdgeTec's Pack Station case taping machine can be learned in minutes, avoiding breaks in production and downtime, saving your company money and increasing your ROI.

## THE RIGHT SOLUTION

Rugged design. Proven reliability. Simple operation. Your benefits go on and on. When it comes to industrial operation, rely on EdgeTec to provide the right solution for your case sealing needs.

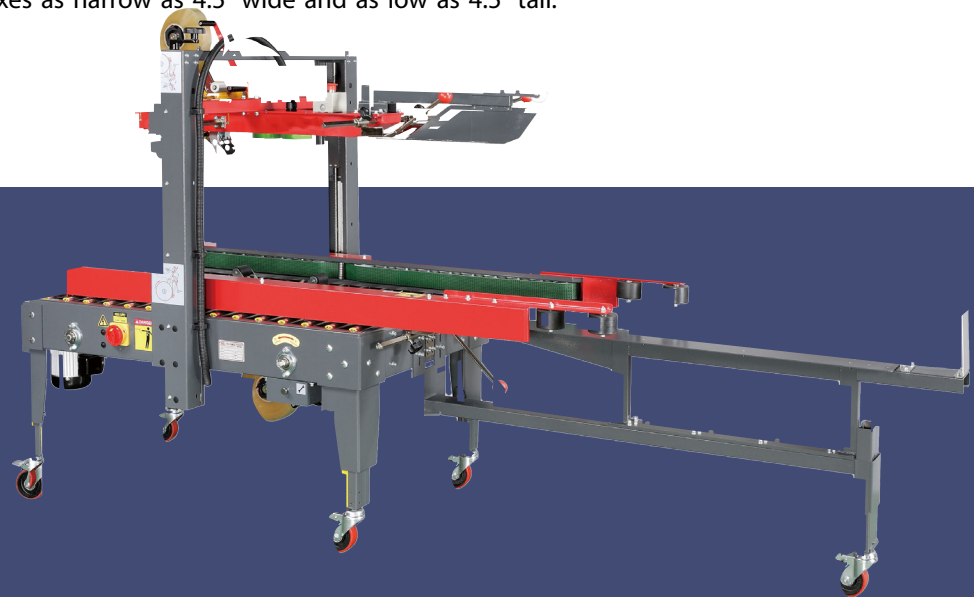

Distributed  
by:

# EdgeTec

## TAPERS



PACK STATION FEATURES		PACK STATION TAPING SPECIFICATIONS			
<ul style="list-style-type: none"> <li>Utilizes EdgeTec's Easy Swap Tape Head</li> <li>Anvil packing station for easy case packing</li> <li>Plug-in and go operation</li> <li>Powder coated 12 gauge steel</li> <li>Top and bottom tape heads</li> <li>Industrial strength side belts</li> <li>Adjustable leg extensions</li> <li>Fast and easy box size changes</li> <li>Low maintenance</li> <li>Accommodates wide case range</li> <li>Casters for transportation within plant</li> </ul>	Sealer Tape	Uniform side belt, top and bottom case sealer			
	Machinery Makeup	Industrial strength 12 gauge steel, powder coated for durability			
	Belt Speed	65 feet/per minute			
	Tape Speed	12 cases/per minute, depending on box size and operator efficiency			
	Conveyor Height Adj.	20" to 32.3"			
	BOX SPECIFICATIONS	Length	Width	Depth	
	Minimum Box Size	4.5"	3.5"	3.5"	
	Maximum Box Size	Infinite	19.7"	19.7"	
	Tape Size	2" wide pressure sensitive tape, up to 15" diameter rolls, optional 3" wide tape			
	Tape Head	Proven design requires no lubrication, designed for simple tape threading, removable for maintenance and interchangeable with top or bottom cartridges			
Air Requirements	None				
Electrical Requirements	110 VAC, 60Hz, 4.0A				
Agency Approvals	CE Certification				
PACK STATION OPTIONAL ACCESSORIES					
3" Tape Head	Accepts 3" wide tape rolls				
Front Packing Table	Roller table bolts before taping system to allow for case movement; replaces anvil packing station				
Rear Packing Table	Roller table bolts after taping system to allow for case movement				